



ECH Extractors

Manual for Installation, Use and Maintenance



|C|D|A|

Important

The CDA Group Ltd cannot be held responsible for injuries or losses caused by incorrect use or installation of this product. Please note that CDA reserve the right to invalidate the guarantee supplied with this product following incorrect installation or misuse of the appliance or use in a commercial environment.

This appliance is not designed to be used by people (including children) with reduced physical, sensorial or mental capacity, or who lack experience or knowledge about it, unless they have had supervision or instructions on how to use the appliance by someone who is responsible for their safety.

Under no circumstances should any external covers be removed for servicing or maintenance except by suitably qualified personnel.

Appliance information:

Please enter the details on the appliance rating plate below for reference, to assist CDA Customer Care in the event of a fault with your appliance and to register your appliance for guarantee purposes.

Appliance Model	<input type="text"/>
-----------------	----------------------

Serial Number	<input type="text"/>
---------------	----------------------

CE Declarations of Conformity:

This appliance has been manufactured to the strictest standards and complies with all applicable legislation, including Gas safety, Electrical safety (LVD) and Electromagnetic interference compatibility (EMC).

IMPORTANT INFORMATION FOR CORRECT DISPOSAL OF THE PRODUCT IN ACCORDANCE WITH EC DIRECTIVE 2002/96/EC.

At the end of its working life, the product must be taken to a special local authority waste collection centre or to a dealer providing appliance recycling services.

Disposing of a household appliance separately avoids possible negative consequences for the environment and health. It also enables the constituent materials to be recovered, saving both energy and resources. As a reminder of the need to dispose of household appliances separately, the product is marked with a crossed-out wheeled dustbin.

Please note:

- Under no circumstances should the extractor be connected to any gas ventilation system, flue system or hot air ducting system.
- Do not vent the extractor into an attic or loft space.
- Only house the extractor in rooms with adequate ventilation. Remember that the extractor is powerful and whatever air is extracted needs to be replaced.
- Do not tile the extractor in. It should be removable for service or maintenance.
- Do not use silicone sealant to secure the hood to the wall.
- You must be able to isolate the extractor from the mains electrical supply after installation.
- This extractor has been designed to be used in a room with a volume of less than 36 m³.
- Steam cleaners must not be used when cleaning this appliance.
- The performance of your extractor will vary depending on a number of factors. These include: type of extraction, length of ducting, room volume, ventilation available and cleanliness of the filters.

Using your Extractor

For best performance, you should switch on the extractor 15 minutes before starting to cook and leave it to run for approximately 15 minutes after the end of cooking.

Control Panel

A – Power indicator light

B – Light button

C – Power off button

D – Speed level buttons

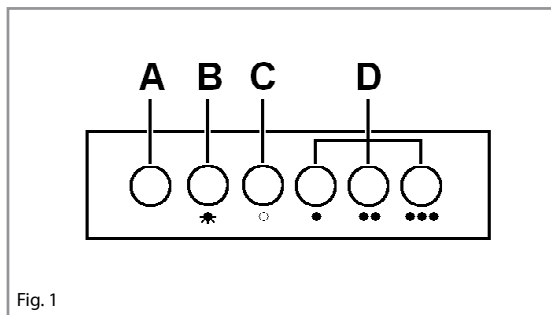

Fig. 1

To switch the extractor light on or off

- Press button B.

To switch on the extractor or to change the speed at any time when the extractor is running

- Press the relevant D button for the first, second or third speed level as required.

To switch the extractor off

- Press the C button.

Care and Maintenance

IMPORTANT : DO NOT PERFORM MAINTENANCE OR CLEANING OF THE EXTRACTOR WITHOUT FIRST SWITCHING OFF THE ELECTRICITY SUPPLY.

Cleaning

You should use a nonabrasive cleaner. Any abrasive cleaner (including Cif) will scratch the surface and could erase the control panel markings.

You can clean your extractor effectively by simply using a dilute solution of water and mild detergent and drying to a shine with a clean cloth, for example the CDA E-Cloth.

Cleaning the grease filter

The grease filter should be kept clean to minimise the risk of fire.

At least once a month you should remove and clean the grease filter with hot soapy water. You can also wash the grease filter in a dishwasher, ensuring that you place it in an upright position to prevent damage from other items in the dishwasher. After rinsing and drying, replace the filter.

To remove the grease filter, push in the button on the handle and then pull down on the filter at the front as shown in figure 2. When you have released it at the front, then you can pull the filter out completely.

Please note:

Cleaning the grease filter in the dishwasher may lead to discoloration. This is normal and does not constitute a fault with the appliance.

Changing the charcoal filter (re-circulating only)

To ensure best performance of your extractor, you should replace the charcoal filters every four to six months, depending on use. To attach a new charcoal filter, first remove the grease filter as described above. Then offer up the charcoal filter to the side of the motor as shown in figure 3 and turn it clockwise until it locks into place.

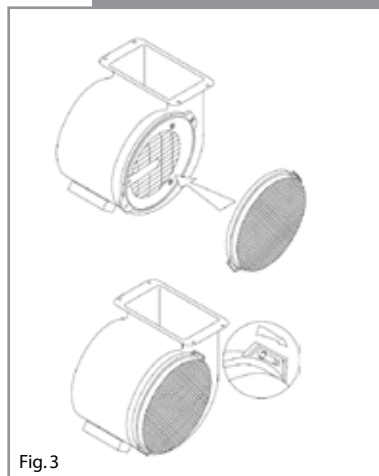
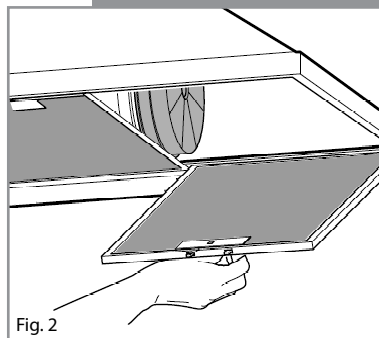



Changing the Light

DO NOT CHANGE THE LIGHT BULB IMMEDIATELY AFTER USE AS THE BULB WILL BE HOT. ALLOW IT TO COOL BEFORE REMOVING IT.

Remove the grease filter, unscrew the light bulb and replace the light with the required light bulb as shown below. Finally, replace the grease filter.

ECH	50W max halogen 2 pin GU10
-----	----------------------------

Table 1

Do not touch bulbs or adjacent areas during or straight after prolonged use of the lights.

The light is designed for use during cooking and not for general room illumination. Extended use of the light can reduce the life span of the bulb.

Bulb replacement is not covered by the guarantee.

Only use bulbs recommended for your extractor. Do not fit bulbs of a higher power rating. Bulbs of a lower power rating may be adequate for use, generally last longer and use less energy.

Spare bulbs are available from CDA Customer Care or from your local DIY shop.

Mains Electricity Connection

THIS APPLIANCE MUST BE CONNECTED TO THE MAINS SUPPLY BY A COMPETENT PERSON, USING FIXED WIRING VIA A DOUBLE POLE SWITCHED FUSED SPUR OUTLET AND PROTECTED BY A 3A FUSE.

We recommend that the appliance is connected by a qualified electrician, who is a member of the N.I.C.E.I.C. and who will comply with the I.E.E. and local regulations.

The wires in the mains lead of this appliance are coloured in accordance with the following code:

BLUE = NEUTRAL, BROWN = LIVE.

As the colours of the wires in the mains lead for the appliance may not correspond with the coloured markings identifying the terminals connecting to the fused spur, proceed as follows:

- The wire which is coloured blue must be connected to the terminal marked N (Neutral), or coloured black.
- The wire which is coloured brown must be connected to the terminal marked L (Live), or coloured red.
- If the mains cable is damaged, it must be replaced by a CDA approved engineer, agent or similarly qualified persons in order to avoid a hazard.

NOTE: USE A 3A FUSE

Assembly and electrical connection should be carried out by competent personnel.

When installing this product we recommend you seek the help of another individual.

IMPORTANT: THIS APPLIANCE IS A CLASS II APPLIANCE (DOUBLE INSULATED) AND IS NOT INTENDED TO BE EARTHED. DO NOT FIT AN EARTH LEAD TO THIS EXTRACTOR.

Do not mount the isolation switch behind the chimney section. It is a requirement that you must be able to isolate the extractor from the mains electrical supply after installation.

This appliance is intended to be connected to the mains electrical supply by means of an isolation switch and fused spur and is intended to be protected by a 3A fuse. The use of a 13A fuse can cause damage to the internal wiring in the event of a fault, and may also invalidate the warranty.

DOUBLE POLE SWITCHED FUSED SPUR OUTLET

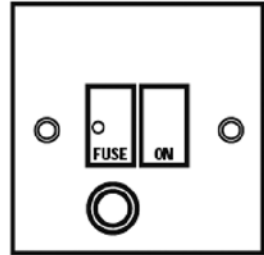

USE A 3 AMP FUSE



Electrical Information

Mains electrical voltage: 230 – 240Vac

Total rated power consumption: 240W

Troubleshooting

Please note:

Your extractor is equipped with a motor protection device that will switch off the motor to prevent damage from overheating. This may happen during cooking when most or all of the zones/burners are being used simultaneously, or if your extractor is installed incorrectly, lower than the recommended height.

This is normal, and the extractor will work again once the motor has cooled sufficiently.

If your extractor is not working:

1. Check that the mains supply has not been switched off.
2. Check that the fuse in the spur has not blown.

Contact CDA Customer Care

A : Customer Care Department, The CDA Group Ltd, Harby Road, Langar, Nottinghamshire, NG13 9HY

T : 01949 862 012 F : 01949 862 003 E : customer.care@cda.eu W : www.cda.eu

Mounting your Extractor

When the extractor is to be installed above an electric hob, the minimum distance between the hob and extractor must exceed 600mm (650mm is recommended).

When the extractor is to be installed above a gas hob, the minimum distance between the hob and extractor must exceed 700mm (750mm is recommended).

If the instructions provided with your gas hob state that the required distance between the hob and extractor must be greater than 700mm, then that is the distance that should be observed; this is a legal requirement and may lead to your hob being disconnected from the gas supply and the installation being reported to RIDDOR (The height should be measured from the top of the burners).

IN THE ABSENCE OF ANY INSTRUCTIONS SUPPLIED WITH THE GAS HOB, THE MINIMUM DISTANCE BETWEEN THE HOB AND EXTRACTOR MUST BE AT LEAST 760mm.

The width of any hob must not be greater than the width of the extractor installed above it.

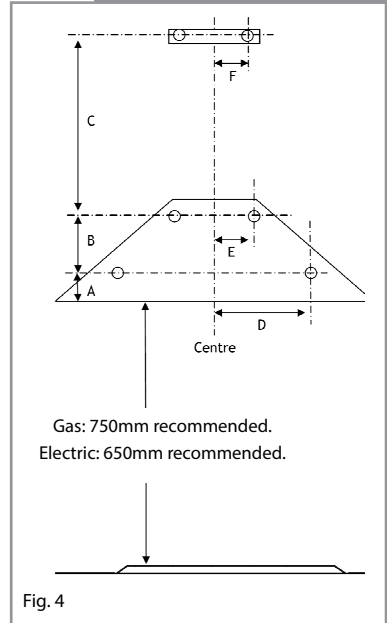

	ECH61/ ECH71	ECH91/ ECH101
A	55	55
B	210	210
C	400	400
D	203	303
E	75	75
F	65	65

Table 2

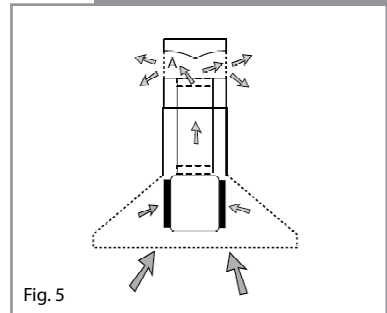

INSTALLATION

Tools required

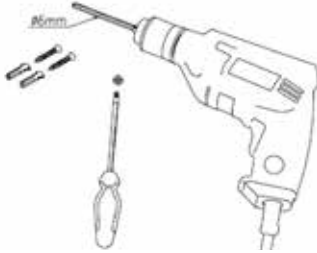

Fig. 6

Mark wall as required (see table 2)

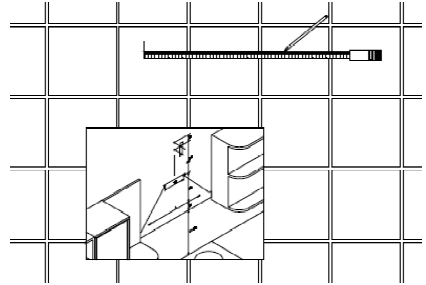

Fig. 7

Drill holes

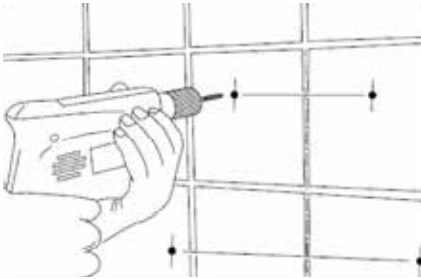

Fig. 8

Fit wall fixings and top screws - Ensure that any fixings you use are appropriate for the wall type.

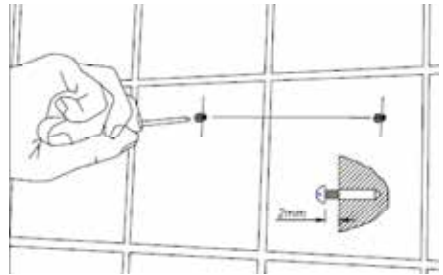

Fig. 9

Secure hood (tighten all screws)

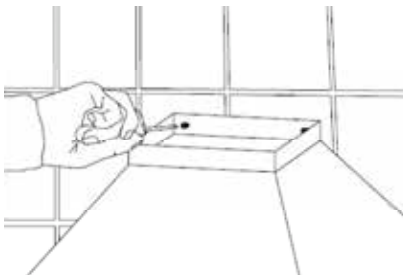

Fig. 10

Fit ducting adaptor

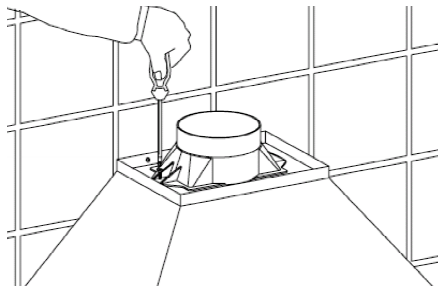

Fig. 11

IMPORTANT SAFETY WARNING: ONLY USE THE SCREWS PROVIDED WITH THE EXTRACTOR TO MOUNT THE DUCTING ADAPTOR. THE USE OF LONGER SCREWS MAY CAUSE DAMAGE TO THE INTERNAL WIRING WHICH WILL NOT BE COVERED BY THE GUARANTEE.

Mount chimney brackets

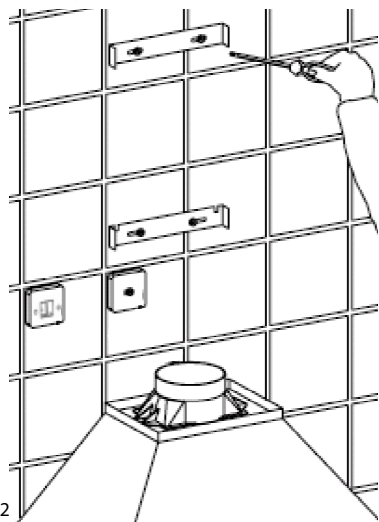

Fig. 12

Fix ducting (seal joint)

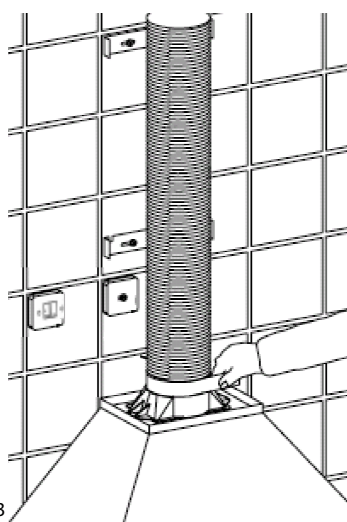

Fig. 13

Mount the chimney

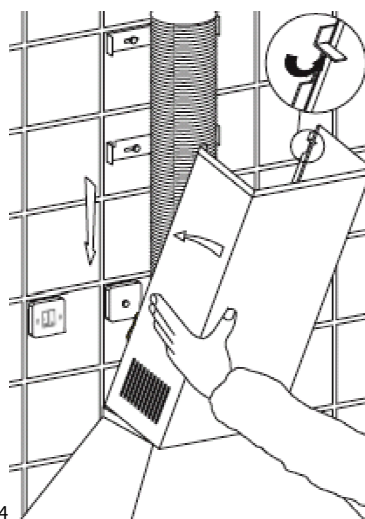

Fig. 14

Adjust and secure the chimney

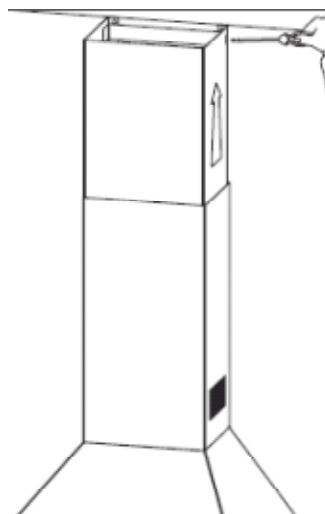

Fig. 15

Ducting and Ventilation

For best performance and lowest noise output, we recommend the use of 125mm ducting. 100mm ducting may be used but this will reduce performance and increase the noise of the extractor.

Energy Efficiency Information			
Attribute	Symbol	Value	Units
Model Identification		echxx	
Annual Energy Consumption	AEC_{Hood}	135.4	kWh
Time increase factor	f	1.7	
Fluid Dynamic Efficiency	FDE_{Hood}	9.3 (E)	
Energy Efficiency Index	EEl_{Hood}	106.9 (E)	
Measured airflow at Best Efficiency Point	Q_{BEP}	227.7	m^3/h
Measured Pressure at Best Efficiency Point	P_{BEP}	150.0	Pa
Maximum airflow	Q_{MAX}	427.4	m^3/h
Measured electric power at Best Efficiency Point	W_{BEP}	102.5	W
Nominal lighting power	WL	100.0	W
Average illumination of the lighting system on the cooking surface	E_{Middle}	665.0	Lux
Measured power consumption in standby	P_S	NA	W
Measured power consumption off mode	P_O	0.0	W
Sound power level	L_{WA}	64.0	dBA
Grease Filter Efficiency	GFE_{Hood}	80.5 (C)	%
Lamp efficiency	LE_{Hood}	6.7 (F)	%

E & O E. All instructions, dimensions and illustrations are provided for guidance only. CDA reserve the right to change specifications without prior notice.



To contact our Customer Care Department, or for Service,
please contact us on the details below.